

AP MASH 4CBL Anchor Post

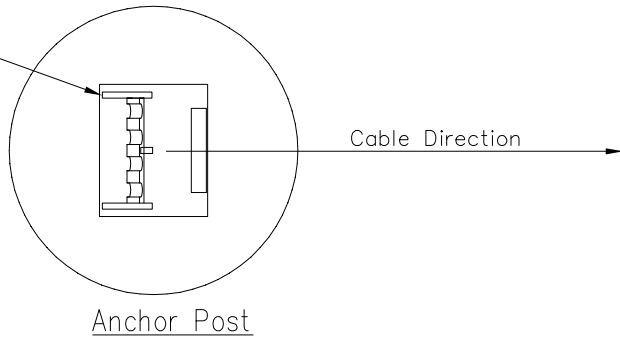

PROPRIETARY TO GIBRALTAR



MASH 2016 TL3
Mash Terminal Layout

Gibraltar Cable Barrier Systems

Scale:	NTS	Date:	8-26-21
Layout:	ANSI B	Drafter:	BH

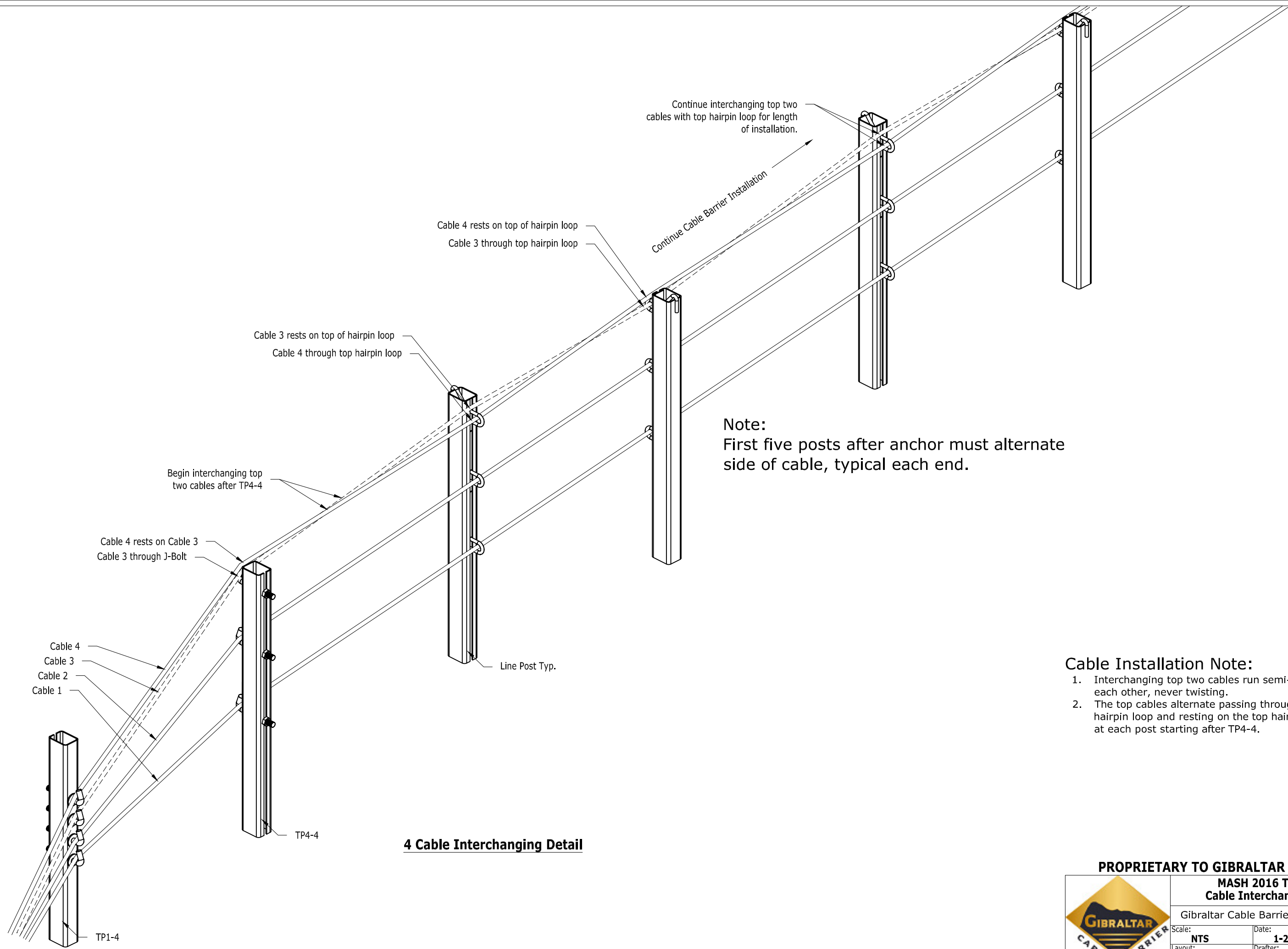

Continue interchanging top two cables with top hairpin loop for length of installation.

Continue Cable Barrier Installation

Cable 4 rests on top of hairpin loop
Cable 3 through top hairpin loop

Cable 3 rests on top of hairpin loop
Cable 4 through top hairpin loop

Begin interchanging top two cables after TP4-4

Cable 4 rests on Cable 3
Cable 3 through J-Bolt

Cable 4
Cable 3
Cable 2
Cable 1

Line Post Typ.

TP4-4

TP1-4

Note:
First five posts after anchor must alternate side of cable, typical each end.

4 Cable Interchanging Detail

Cable Installation Note:

1. Interchanging top two cables run semi-parallel to each other, never twisting.
2. The top cables alternate passing through the top hairpin loop and resting on the top hairpin loop at each post starting after TP4-4.

PROPRIETARY TO GIBRALTAR



MASH 2016 TL4 Cable Interchanging	
Gibraltar Cable Barrier Systems	
Scale: NTS	Date: 1-2-19
Layout: ANSI B	Drafter: JP

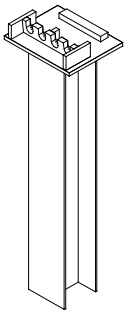

AP-MASH-4CBL
MASH Anchor Post

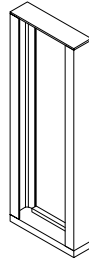

CRP-MASH-4CBL
MASH Cable Release Post

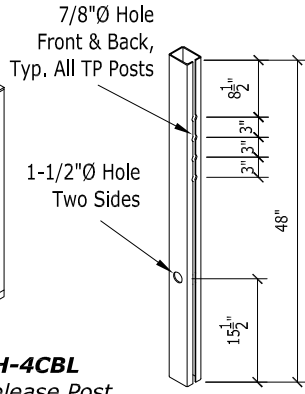

TP1-4
Terminal Post
No. 1/Weak

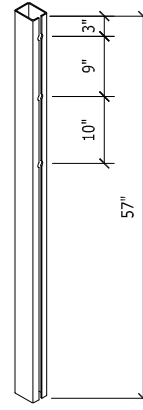

TP4-4
Terminal Post

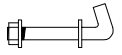

J-BLT
J-Bolt



RH STUD ATF ASSY
Anchor Terminal Fitting RH Stud



ATF
Anchor Terminal Fitting



ATF-END
Anchor Terminal Fitting End

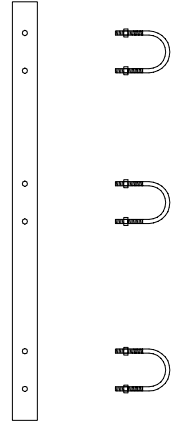

U-Bolt Lock-Plate Assembly

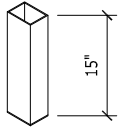

Tube Socket
(Steel or Plastic)

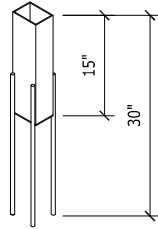

SOCK-S
Short Rebar Socket

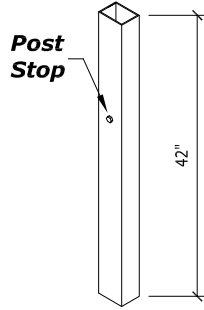

TUBE-D
Driven Socket

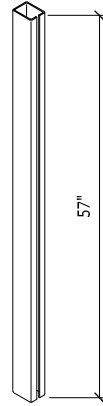

4-LNP-S
Line Post/Socketed

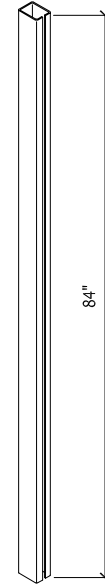

4-LNP-D
Line Post/Driven



4-HPIN Alum.
3 Cable Alum. HPIN

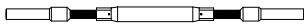

RH/LH SWAGE ASSY



CSTB
Cable Splice Turnbuckle

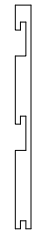

4-LOCK
TL4 Lockplate



WEDGE



ACORN
Acorn w/ Wedge



TORP
Longitudinal Section ONLY
Torpedo Cable Splice

PROPRIETARY TO GIBRALTAR



MASH 2016 TL4 System Parts

Gibraltar Cable Barrier Systems

Scale:	NTS	Date:	8/26/21
Layout:	ANSI B	Drafter:	BH